

MEDIDA DO PRODUTO MONTADO

MEASURE OF THE ASSEMBLED PRODUCT
MEDIDA DEL PRODUCTO ENSAMBLADO

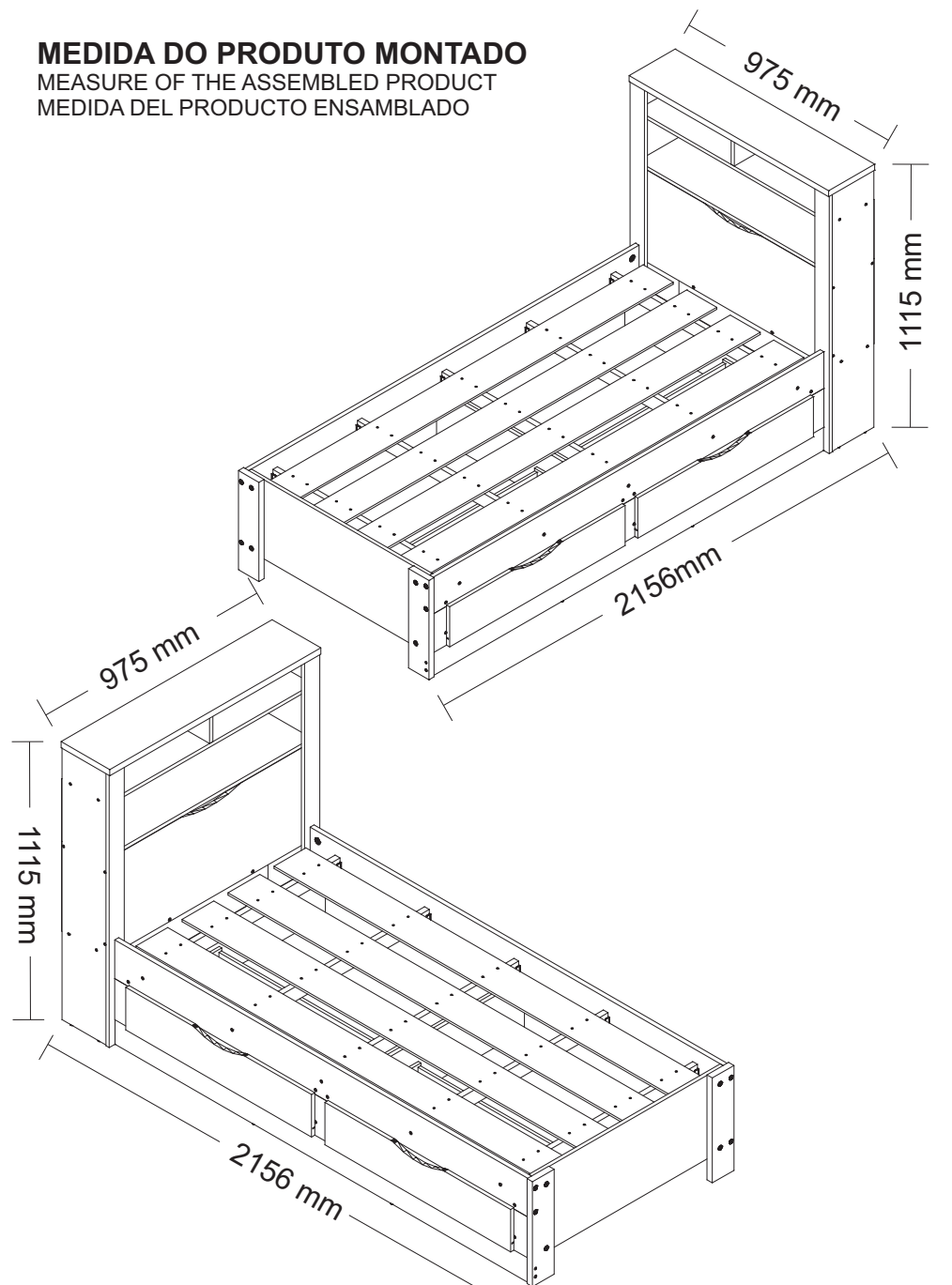

+55 (43)3538-8300

CAMA SOLTEIRO INVICTA COM GAVETAS

SINGLE BED INVICTA WITH DRAWERS
CAMA INDIVIDUAL INVICTA CON CAJONES

ESQUEMA DE MONTAGEM 949181-06

ASSEMBLING INSTRUCTIONS
MANUAL DE ARMADO

santos
Andirá



“Montagem opcional DIREITA”
“Optional RIGHT mounting”
“Montaje opcional DERECHA”
PÁG. 7, 8, 9, 10, 11, 12 e 13.

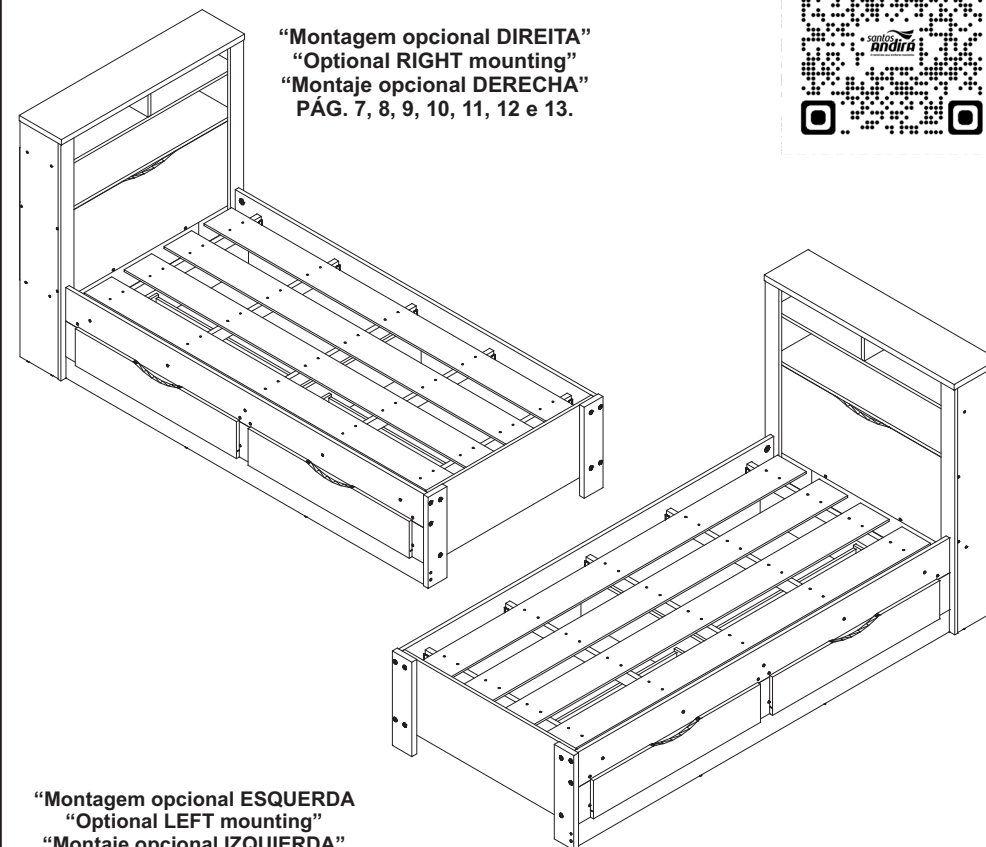

“Montagem opcional ESQUERDA”
“Optional LEFT mounting”
“Montaje opcional IZQUIERDA”
PÁG. 7, 8, 9, 14, 15, 16 e 17.



60 minutos
60 minutes

225844 • JATOBÁ/JATOBÁ
225855 • ATACAMA/ATACAMA
225866 • BRANCO/BRANCO
225899 • ÉBANO/ÉBANO

www.santosandira.com.br

AVISO

Para limpeza do seu móvel utilize flanela seca ou levemente umedecida, sem produtos químicos!

WARNING

To clean your mobile use dry cloth or slightly moistened, no chemicals!

ADVERTENCIA

Para limpiar su mueble use un paño seco o ligeramente humedecido, sin productos químicos!



ISO 14001



ISO 9001



Descarte os resíduos de forma seletiva!

Dispose of waste selectively!

¡Deseche los residuos de manera selectiva!

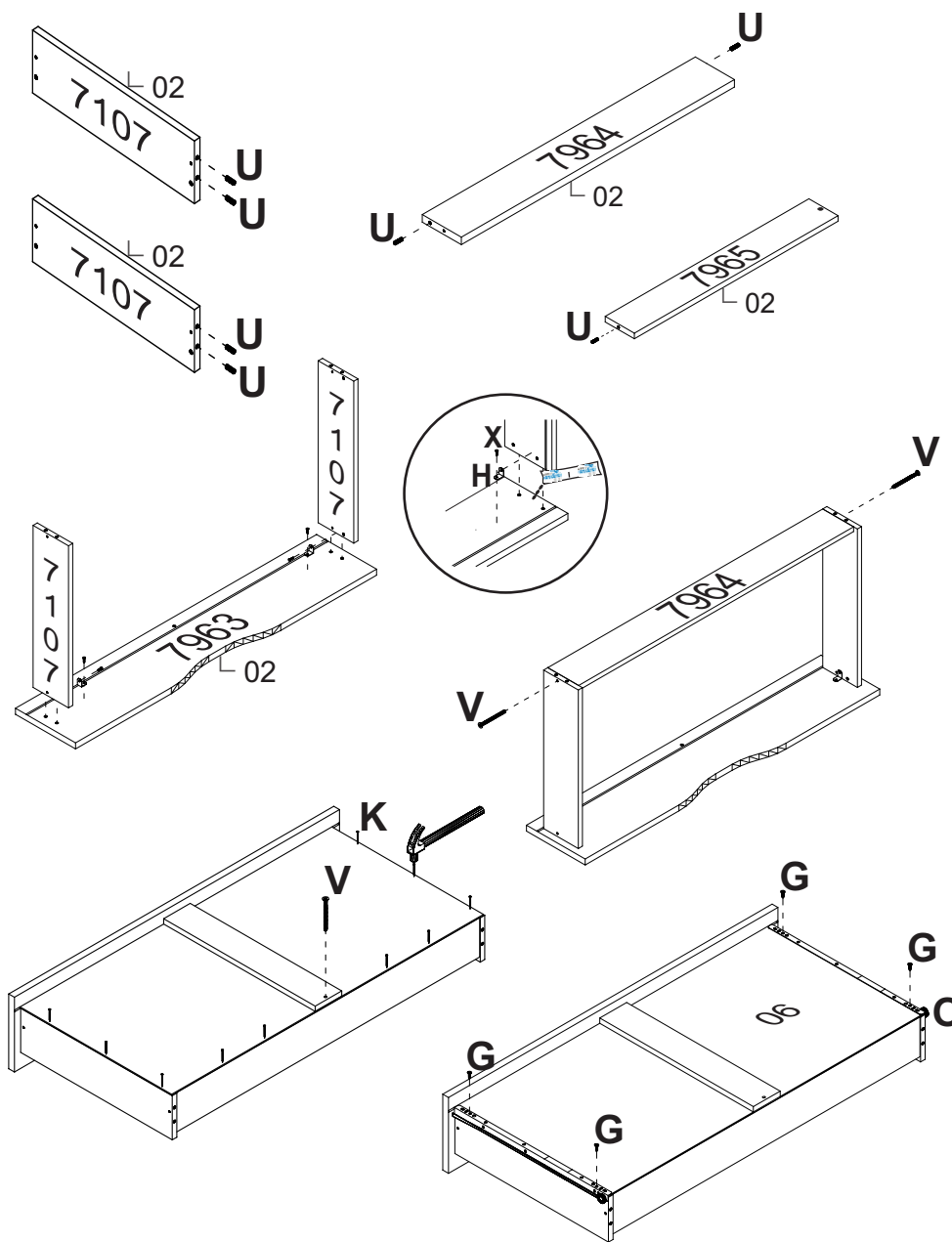

“Usar cola em todas as cavilhas”

“Use glue on all wood pegs”

“Utilizar cola en todos los tarugos de madera”

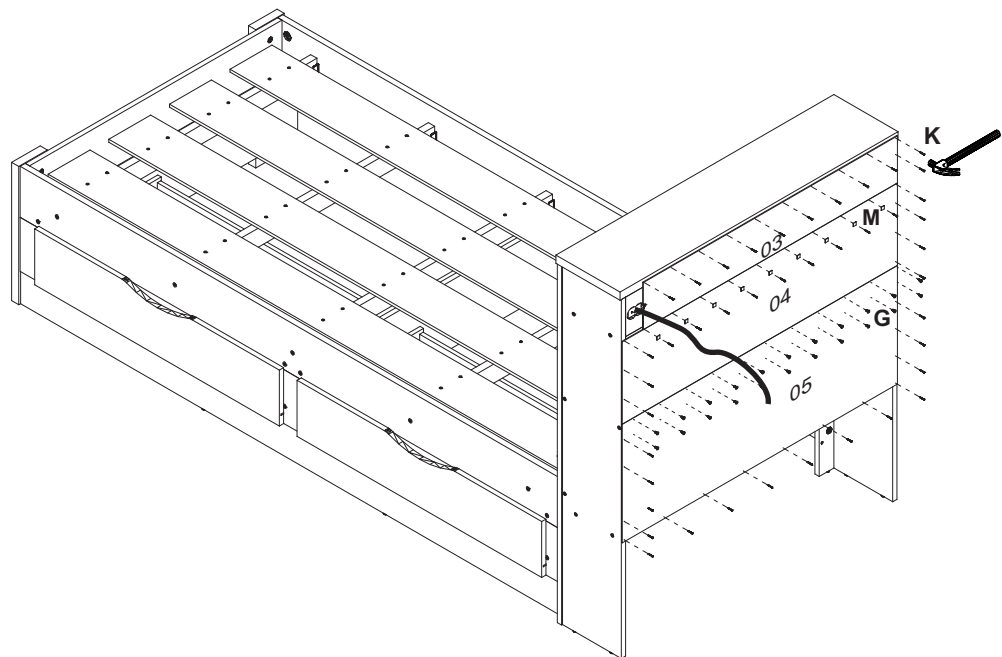

AVISO

**Para instalação elétrica contrate um ELETRICISTA
A fiação da tomada NÃO acompanha o produto!**

WARNING

**For electrical installation hire an ELECTRICIAN
Plug wiring is NOT included with the product!**

ADVERTENCIA

**Para la instalación eléctrica contrate un ELECTRICISTA
El cableado de la toma NO acompaña al producto!**







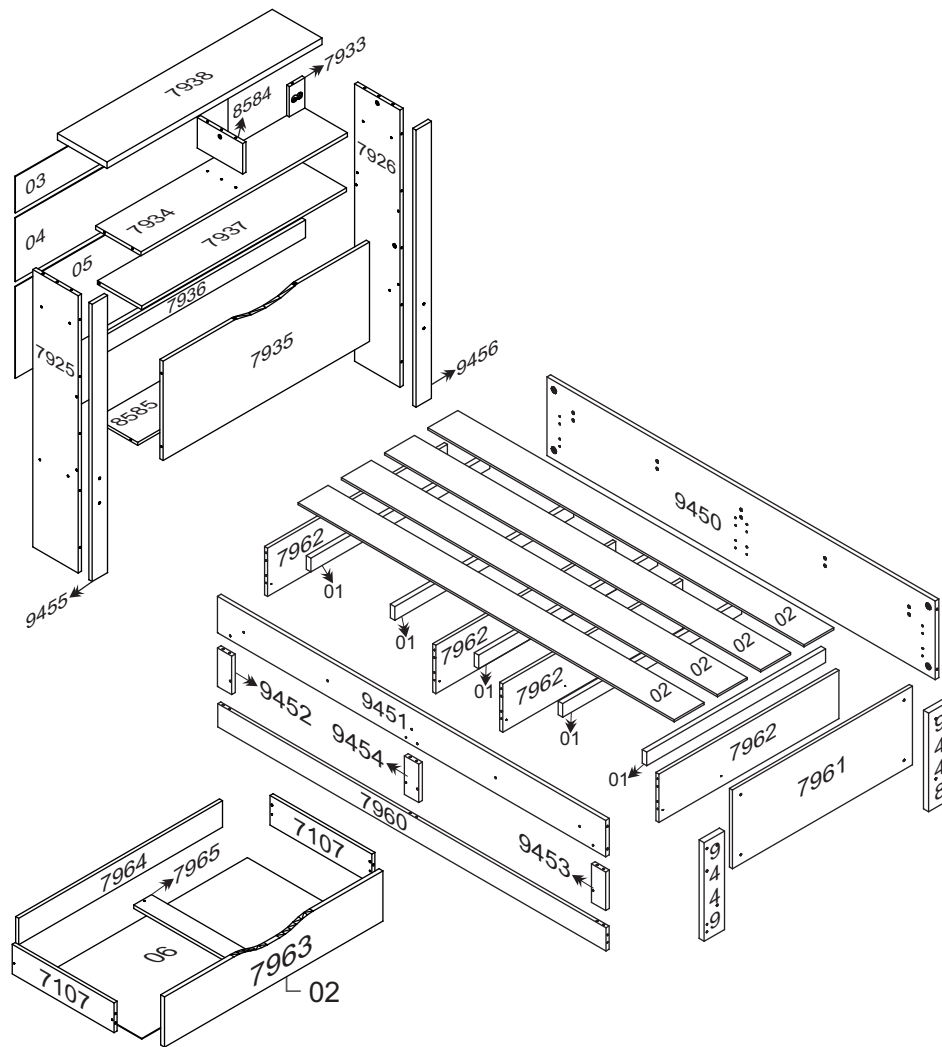





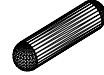

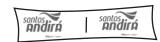
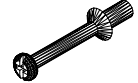

O peso máximo da carga exibido no desenho refere-se a objetos distribuídos de maneira uniforme sobre toda a área de contato da peça.

The maximum loading weight the image shows refers to objects distributed uniformly over the whole part contact area.

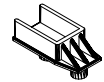
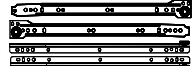
El peso máximo de carga informado en el diseño se refiere a objetos distribuidos uniformemente sobre totalidad de la área de contacto de la pieza.

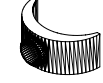

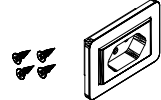
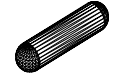
RELAÇÃO DE ACESSÓRIOS
LIST OF ACCESSORIES • LISTA DE ACCESORIOS

A 46  PARAFUSO FI CH PH 4,5x60 SCREW FI CH PH 4,5x60 TORNILLO FI CH PH 4,5x60	B 10  PREGO 12x12 NAIL 12x12 CLAVO 12x12	C 10  SAPATA REDONDA 14mm ROUND SHOE 14mm SAPATA REDONDA 14mm	D 22  CAVILHA MADEIRA 6x40 WOOD PEG 6x40 TARUGO DE MADEIRA 6x40
E 08  CANTONEIRA METAL BRACKET METAL CANTONEIRA METAL	F 05  CASTANHA GIROFIX 15mm MINIFIX 15mm MINIFIX 15mm	G 48  PARAFUSO FI CH PH 4,0x12 SCREW FI CH PH 4,0x12 TORNILLO FI CH PH 4,0x12	H 16  PORCA CILINDRICA 12x09 CYLINDRICAL NUT 12x09 TUERCA CILINDRICA 12x09
I 01  COLA PVA GLUE PVA COLA PVA	J 05  PINO GIROFIX 35mm GIROFIX PIN 35mm TORNILLO DEL GIROFIX 35mm	K 81  PREGO 10x10 NAIL 10x10 CLAVO 10x10	L 03  TAMPA GIROFIX 15mm GIROFIX COVER 15mm TAPA DEL GIROFIX 15mm
M 11  FIXADOR DE FUNDO BACKBOARD'S FIXER FIJADOR DEL COSTADO	N 10  SUPORTE PARA TRAVESSA CROSSBAR SUPPORT SOPORTE PARA LARGUERO	O 02  CONJ. CORREDIÇA METAL 400mm SET OF METAL SLIDES 400mm CONJ. DE RIELES DE METAL 400m	P 08  PARAFUSO LE PH BI 1/4x60 SCREW LE PH BI 1/4x60 TORNILLO LE PH BI 1/4x60
Q 08  PORCA METAL METAL NUT TUERCA METALICA	R 04  PARAFUSO LE PN BI 1/4x40 SCREW LE PN BI 1/4x40 TORNILLO LE PN BI 1/4x40	S 04  PORCA 1/4 QD NUT SX 1/4 QD TUERCA 1/4 QD	T 01  TOMADA ELÉTRICA ELECTRICAL OUTLET TOMA ELÉCTRICA
U 44  CAVILHA MADEIRA 6x25 WOOD PEG 6x25 TARUGO DE MADEIRA 6x25	V 46  PARAFUSO FI CH PH 3,5x35 SCREW FI CH PH 3,5x35 TORNILLO FI CH PH 3,5x35		

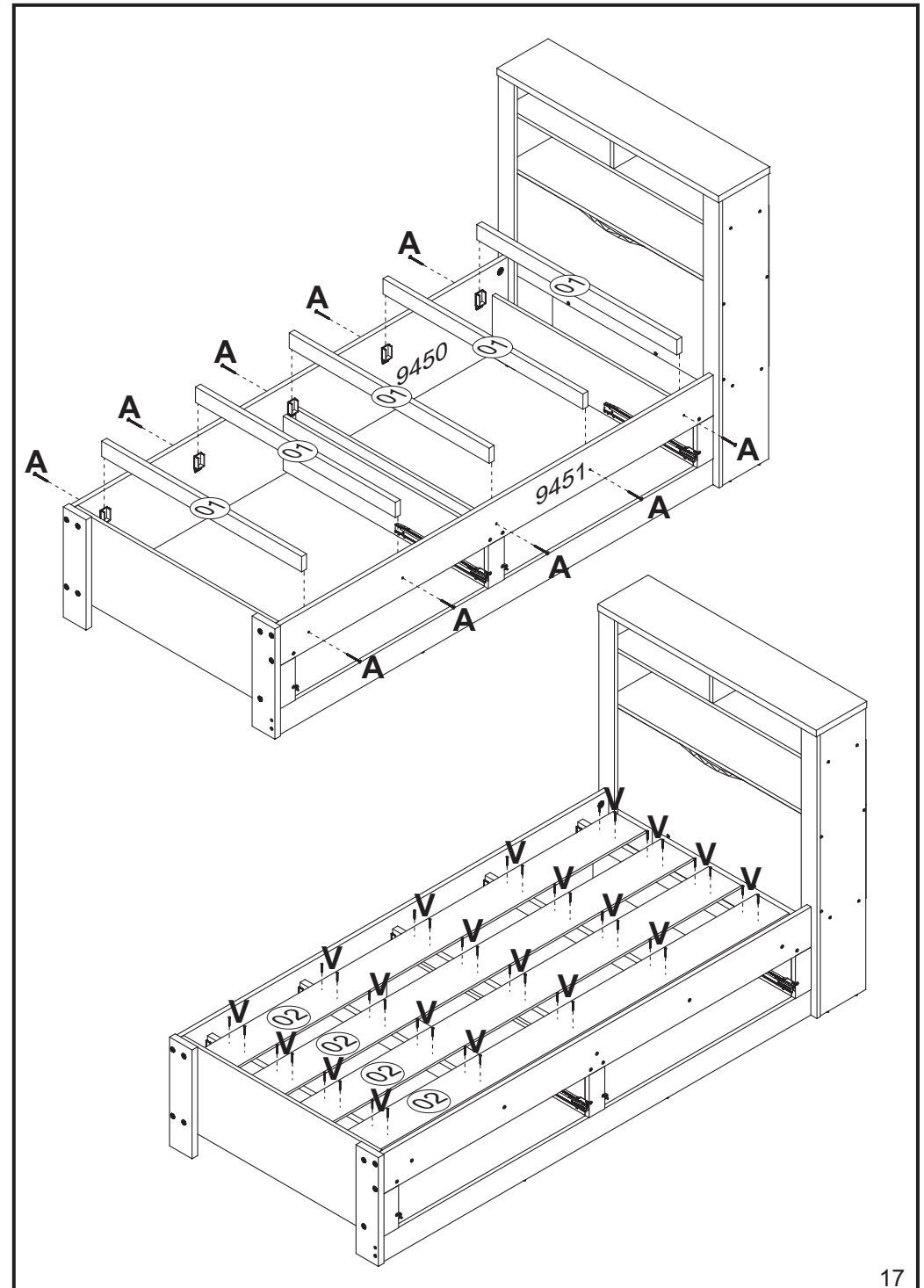

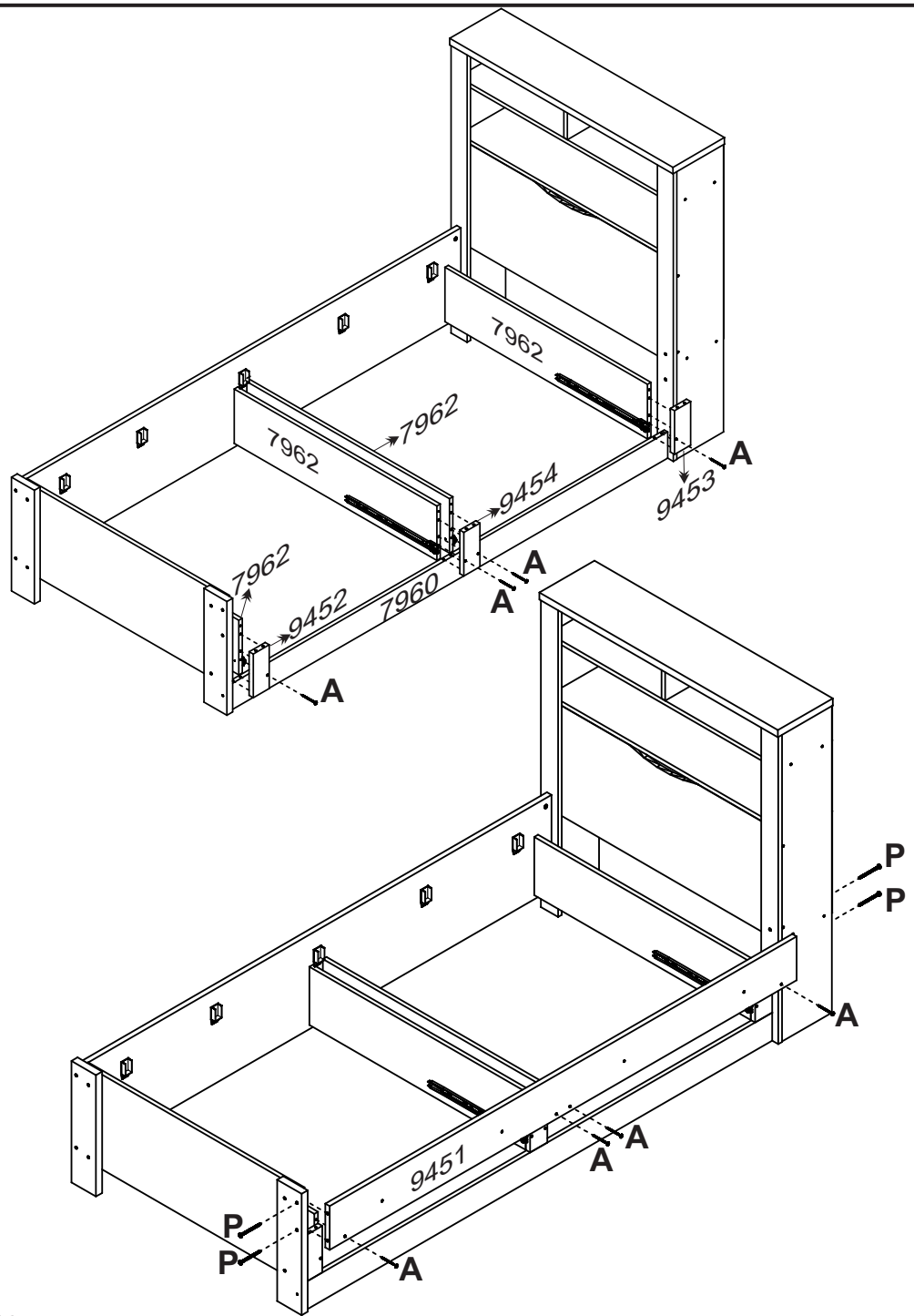

RELAÇÃO DE PEÇAS LIST OF PARTS • LISTA DE PARTES

DESCRIÇÃO DESCRIPTION DESCRIPCIÓN	VOLUME VOLUME VOLUMEM	NÚMERO NUMBER NÚMERO	DIMENSÃO DIMENSION DIMENSIÓN	QUANTIDADE QUANTITY CANTIDAD
TRASEIRO BACKBOARD COSTADO	01	03	891x143x2,5	01
TRASEIRO BACKBOARD COSTADO	01	04	965x250x2,5	01
TRASEIRO BACKBOARD COSTADO	01	05	965x360x2,5	01
LAT.EXT.ESQUERDA LEFT EXTERNAL SIDE LAT. EXT. IZQUIERDA	01	7925	1090x206x15	01
LAT.EXT.DIREITA RIGHT EXTERNAL SIDE LATERAL EXTERNA DERECHA	01	7926	1090x206x15	01
VISTA PARA TOMADA SOCKET FRONTAGE VISTA PARA TOMADA	01	7933	120x70x12	01
TAMPO COVER TAPA	01	7934	937x206x15	01
PAINEL PANEL PANEL	01	7935	937x390x15	01
TESTEIRA TRASEIRA BACK HEADER TESTERA TRASERA	01	7936	937x70x15	01
TAMPO DO BAÚ CHEST'S COVER TAPA DEL BAÚ	01	7937	930x200x15	01
TAMPO SUPERIOR SUPERIOR COVER TAPA SUPERIOR	01	7938	975x225x25	01
DIVISORIA DIVISION DIVISIÓN	01	8584	206x120x15	01
FUNDO DO BAÚ CHEST'S BOTTOM FONDO DEL BAÚ	01	8585	937x191x12	01
VISTA ESQUERDA LEFT FRONTAGE VISTA IZQUIERDA	01	9455	1090x70x15	01
VISTA DIREITA RIGHT FRONTAGE VISTA DERECHA	01	9456	1090x70x15	01
DESCRIÇÃO DESCRIPTION DESCRIPCIÓN	VOLUME VOLUME VOLUMEM	NÚMERO NUMBER NÚMERO	DIMENSÃO DIMENSION DIMENSIÓN	QUANTIDADE QUANTITY CANTIDAD
TRAVESSA CROSSBAR LARGUERO	02	01	880x58x22	05
RIPA SLAT TABLILLA	02	02	1850x147x09	04
FUNDO DE GAVETA DRAWER'S BOTTOM FONDO DEL CAJÓN	02	06	823x408x2,5	02
LAT. DE GAVETA SIDE DRAWER LATERAL DE CAJÓN	02	7107	400x101x12	04
RODAPÉ FRONTAL FRONT BASEBOARD ZÓCALO FRONTAL	02	7960	1910x99x15	01
PESEIRA FOOTBOARD PIECERA	02	7961	885x335x15	01

RELAÇÃO DE PEÇAS
LIST OF PARTS • LISTA DE PARTES

DESCRIÇÃO DESCRIPTION DESCRIPCIÓN	VOLUME VOLUME VOLUMEM	NÚMERO NUMBER NÚMERO	DIMENSÃO DIMENSION DIMENSIÓN	QUANTIDADE QUANTITY CANTIDAD
DIVISÓRIA DIVISION DIVISION	02	7962	885x206x15	04
FRENTE DE GAV. DRAWER'S FRONT FRENTE DE CAJÓN	02	7963	858x170x15	02
TRASEIRO DE GAV. DRAWER'S BACKBOARD TRASERO DE CAJÓN	02	7964	801x90x12	02
TRAVA LOCK TRABA	02	7965	400x70x12	02
PÉ DIREITO RIGHT FOOT PIES DERECHO	02	9448	420x100x25	01
PÉ ESQUERDO LEFT FOOT PIES IZQUIERDO	02	9449	420x100x25	01
BARRA DA CAMA BED'S BAR BARRA DE CAMA	02	9450	1910x335x18	01
BARRA DA CAMA BED'S BAR BARRA DE CAMA	02	9451	1910x155x18	01
APOIO ESQUERDO LEFT SUPPORT APOYO IZQUIERDO	02	9452	164x70x18	01
APOIO DIREITO RIGHT SUPPORT APOYO DERECHO	02	9453	164x70x18	01
APOIO CENTRAL CENTRAL SUPPORT APOYO CENTRAL	02	9454	164x70x18	01

